

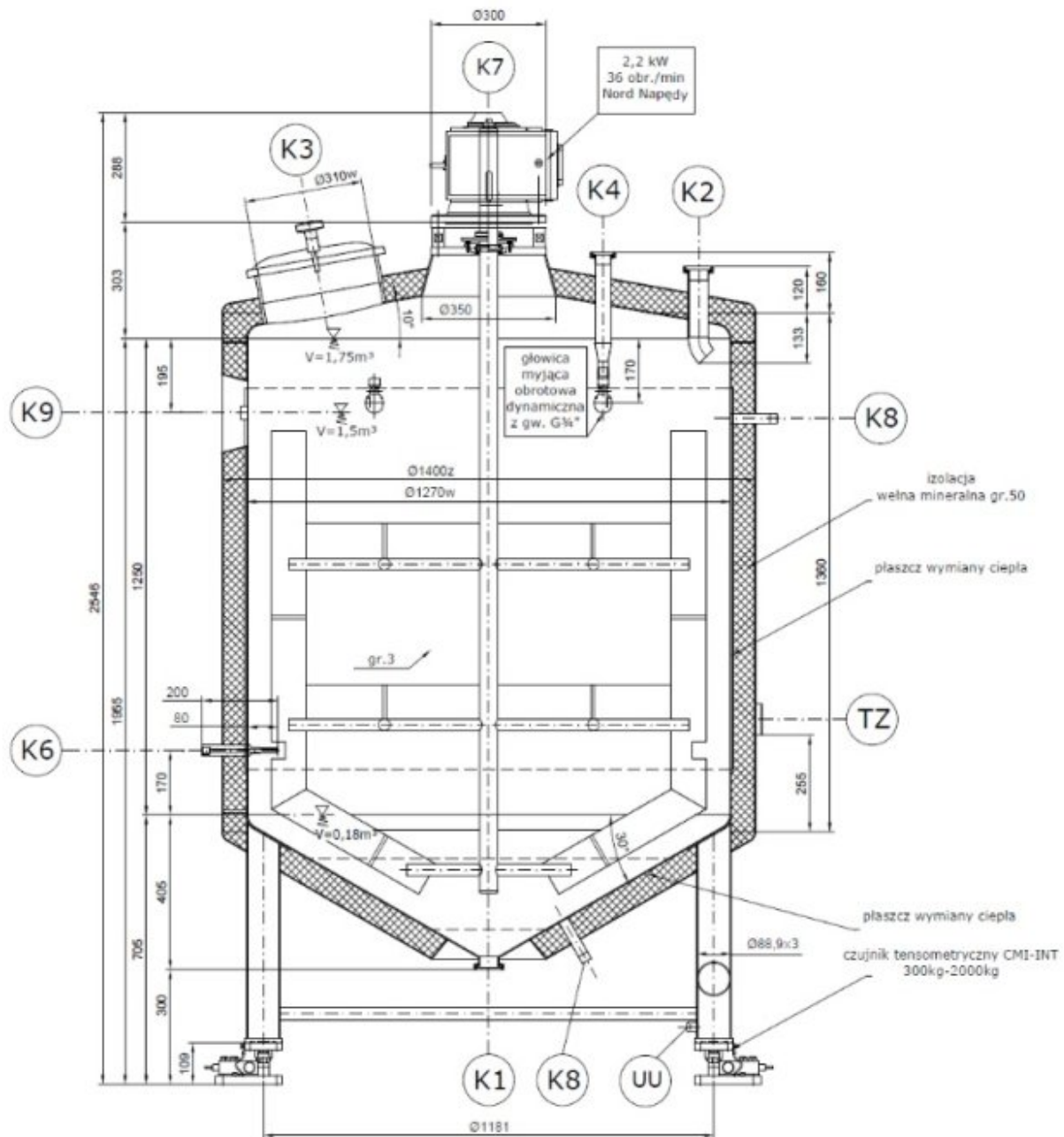

TANK WITH A TOP PADDLE MIXER



The tank is made with a heating/cooling jacket and a frame or paddle mixer, vertical cylindrical, standing on 4 adjustable legs. Legs adapted to be transported with a pallet truck.

Heating mantle made using pillow plates technology.

Welds inside the tank are level (ground to the native material, face removed and polished), external surface - cold-rolled 2B sheet, butt welds on the outside - face removed, fillet welds on the outside etched and mechanically cleaned (face of the weld visible). Insulated tank. Insulation thickness 50 mm. Insulation coverage 2.0 mm. The thickness of the inner tank sheet is 3.0 mm.





Equipment:

- Slow-speed frame or paddle mixer with speed regulation
- Engine power and speed - depending on the tank capacity and the properties of the mixed medium.
Possibility of regulation with an inverter (inverter on the Ordering Party's side)
- Drain connector, e.g. DN50 DIN 11851
- Supply connector, e.g. DN50 DIN 11851
- Sensor connector max
- Breathing port with air vent
- Sampling port
- Upper manhole DN 440
- CIP rotating washing head - 2 pcs

